

# DN-24/BNC-75

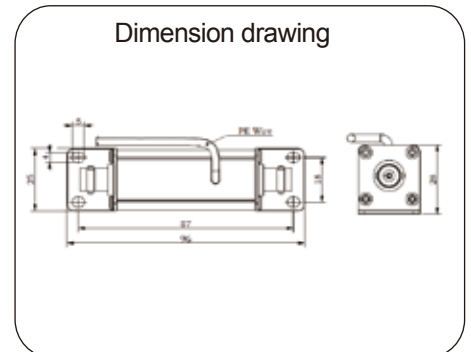
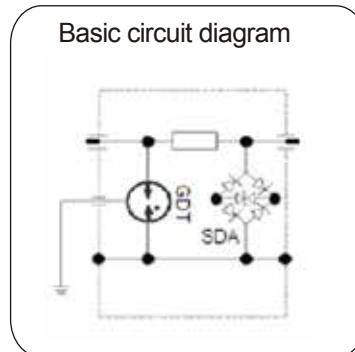

JDA DN-24/BNC-75 surge arrester is designed for coaxial systems protection against the damaging from surges and spikes caused by lightning and other electrical sources, suitable for use in category location B, C (ANSI/IEEE C62.41) or directly at the upstream near the protected devices.

## Technical Features

- ⊙ Data network protector in according with UL497b,IEC61643-21:2012;
- ⊙ High discharge capability, total nominal discharge current up to 20kA 8/20;
- ⊙ Two-stage protection circuit;
- ⊙ Limit the transient with gas discharge tubes and transzorb diodes;
- ⊙ Low insertion loss;

Type		DN-24/BNC-75
In accordance with		UL497b,IEC 61643-21:2012
Nominal voltage (Vdc)	Un	24
Max. continuous operating voltage (Vdc/ac)	Uc	33/23.3
C2 Nominal discharge current(8/20us)	In	10kA
C2 Total nominal Discharge Current ( 8/20us )		20kA
Voltage protection level(V)	L-SG@C2 (8/20μs)Up	<500V
	L-SG@C3 (1KV/μs)Up	<700V
Frequency Range f (MHz)		0~20MHz
Nominal Current IL (A)		0.8A
Modes of Protection		Signal to Shield/Ground, Shield to Ground
Technology		Two-stage protection circuit, GDT/SAD &PTC tech
Insertion loss at 20MHz (dB)		<0.2
VSWR		<1.2
Continuous Power P (w)		80 Watts
Series impedance per line R (Ohm)		2.1 Ohm
Pinning		Line/Shield/PG
Input Connection Type		<b>BNC, 75 Ohm</b>
Output Connection Type		<b>BNC, 75 Ohm</b>
Operating Temperature		-40 C ~ +85 C
Storage Temperature		-40 C ~ +85 C
Operating Humidity		0-95% Non-condensing
Dimensions (mm)		96X 25 X 28

Note: Subject to change without any notice.