

DATA SHEET

METAL OXIDE VARISTOR – 32Ø SERIES

FEATURE

- Wide operating voltage (V1mA) range from 33V to 1600V.
- Fast responding to transient over-voltage.
- Large absorbing transient energy capability.
- Low clamping ratio and no follow-on current.
- Meets MSL level 1, per J-STD-020



APPLICATION

- Transistor, diode, IC, thyristor or triac semiconductor protection.
- Surge protection in consumer electronics.
- Surge protection in industrial electronics.
- Surge protection in electronic home appliances, gas and petroleum appliances.
- Relay and electromagnetic valve surge absorption.

GENERAL CHARACTERISTICS DEFINITION

Operating Temperature - 40°C ~ +85°C
 Storage Temperature - 40°C ~ +125°C

PART NUMBER CODE

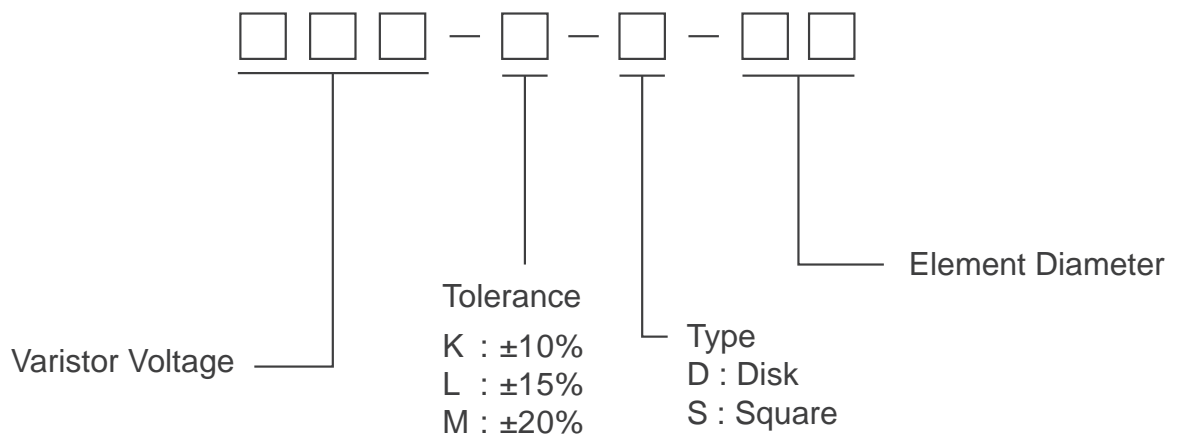

PACKAGE DIMENSIONS

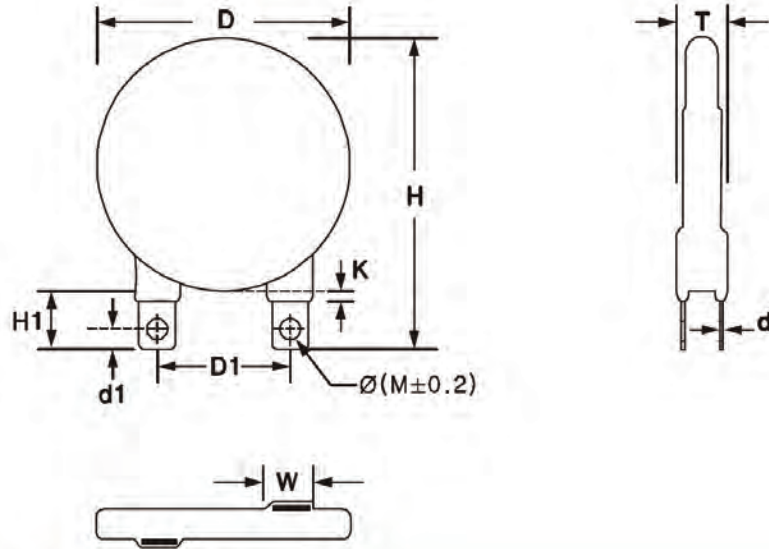

TABLE 1

unit : mm

Symbol	Dimensions
H(max.)	56.3
H1(min.)	14.5
D(max.)	38.0
D1(± 1.0)	25.4
T(max.)	TABLE2
d(± 0.1)	0.5
d1(± 0.3)	3.62
K(max.)	3.18
W(± 0.5)	7.0
$\phi(M\pm 0.2)$	3.2

TABLE 2

unit : mm

Model	T(max.)	Model	T(max.)
330K	6.0	391K	7.3
390K	6.2	431K	7.5
470K	6.4	471K	7.8
560K	6.7	511K	8.0
680K	7.0	561K	8.3
820K	5.7	621K	8.7
101K	5.8	681K	9.0
121K	6.0	751K	9.4
151K	6.3	781K	9.6
181K	6.1	821K	9.8
201K	6.2	911K	10.4
221K	6.3	951K	10.6
241K	6.4	102K	11.2
271K	6.6	112K	11.8
301K	6.8	122K	12.3
331K	6.9	142K	13.3
361K	7.1	162K	14.3

ELECTRICAL CHARACTERISTIC

Part Number	Maximum Allowable Voltage		Varistor Voltage	Maximum Clamping Voltage		Withstanding Surge Current	Maximum Energy (10/1000us)	Typical Capacitance (Reference)
	V _{AC} (V)	V _{DC} (V)	V _{1mA} (V)	I _P (A)	V _C (V)	I(A)	(J)	@1KHZ(pf)
330KD32	20	26	33(29.5~36.5)	40	65	8000	40	30000
390KD32	25	31	39(35~43)	40	77	8000	50	22000
470KD32	30	38	47(42~52)	40	93	8000	60	19000
560KD32	35	45	56(50~62)	40	110	8000	70	16700
680KD32	40	56	68(61~75)	40	135	8000	85	15000
820KD32	50	65	82(74~90)	200	135	20000	100	12800
101KD32	60	85	100(90~110)	200	165	20000	125	10500
121KD32	75	100	120(108~132)	200	200	20000	150	8700
151KD32	95	125	150(135~165)	200	250	20000	190	7000
181KD32	115	150	180(162~198)	200	300	20000	225	5800
201KD32	130	170	200(180~220)	200	340	25000	250	5200
221KD32	140	180	220(198~242)	200	360	25000	270	5150
241KD32	150	200	240(216~264)	200	395	25000	290	5100
271KD32	175	225	270(243~297)	200	455	25000	300	4800
301KD32	190	250	300(270~330)	200	500	25000	330	4550
331KD32	210	275	330(297~363)	200	550	25000	360	4300
361KD32	230	300	360(324~396)	200	595	25000	380	3900
391KD32	250	320	390(351~429)	200	650	25000	400	3200
431KD32	275	350	430(387~473)	200	710	25000	430	3100
471KD32	300	385	470(423~517)	200	775	25000	460	2800
511KD32	320	415	510(459~561)	200	845	25000	510	2700
561KD32	350	460	560(504~616)	200	925	25000	540	2550
621KD32	385	505	620(558~682)	200	1025	25000	570	2400
681KD32	420	560	680(612~748)	200	1120	25000	600	2200
751KD32	460	645	750(675~825)	200	1240	25000	620	2000
781KD32	485	640	780(702~858)	200	1290	25000	660	1900
821KD32	510	670	820(738~902)	200	1355	25000	700	1800
911KD32	550	745	910(819~1001)	200	1500	25000	750	1300
951KD32	575	765	950(855~1045)	200	1570	25000	780	1200
102KD32	625	825	1000(900~1100)	200	1650	25000	810	1100
112KD32	680	895	1100(990~1210)	200	1818	25000	910	1000
122KD32	750	990	1200(1080~1320)	200	1980	25000	960	920
142KD32	880	1140	1400(1260~1540)	200	2310	25000	1020	800
162KD32	1000	1280	1600(1440~1760)	200	2640	25000	1080	700