

TELCOM ESS

TELCOM Energy Storage System



INDEX

NO.	SPEC. DESCRIPTION
1	CABINET 785mm X 2180mm X 640mm IP55、 IP65、 IP66 or IP67 * Outdoor Rack 19" ; IP 65 ; 37U GRP, standard sealing or EPDM sealing *
2	System Architecture Scheme & Single diagram
3	MPPT Charge Controller Charge range of 12Vdc, 24Vdc, 36Vdc, 48Vdc ,60**Vdc Input range : 12 / 24 / 36 / 48 / 60 Vdc ** output voltage: 12 / 24 / 36 / 48 / 60 Vdc **
4	Monitoring PV Input, Output V, Output A, Today Amp Hour (Low/High record), Today Watt Hour(Low/High record) Real Time Charge Status, MPPT Temp., NET Mode, Battery SOC, Battery Status(including V、 A、 Amp Hour、 Temp.), Shunt Connect Status, Voltage sensor Connect Status Local Server 20 years memory, 2 ModBus , 1 EtherNet, web page
5	Battery LiCoxNiyMnzO; 42V-58.8V ; 4.292kWh *
6	DC switch & DC MCCB & MCB
7	Surge Protective Devices 20kA I _{max} 40kA, with fire distinguishing arcing chamber 50KA * UL
8	gPV fuse protection 10KA, 30KA *

* Optional **Specially made, to be advised

Cabinet Physical Properties

General Properties & Dimension



Cabinet Physical Properties

General Properties & Dimension

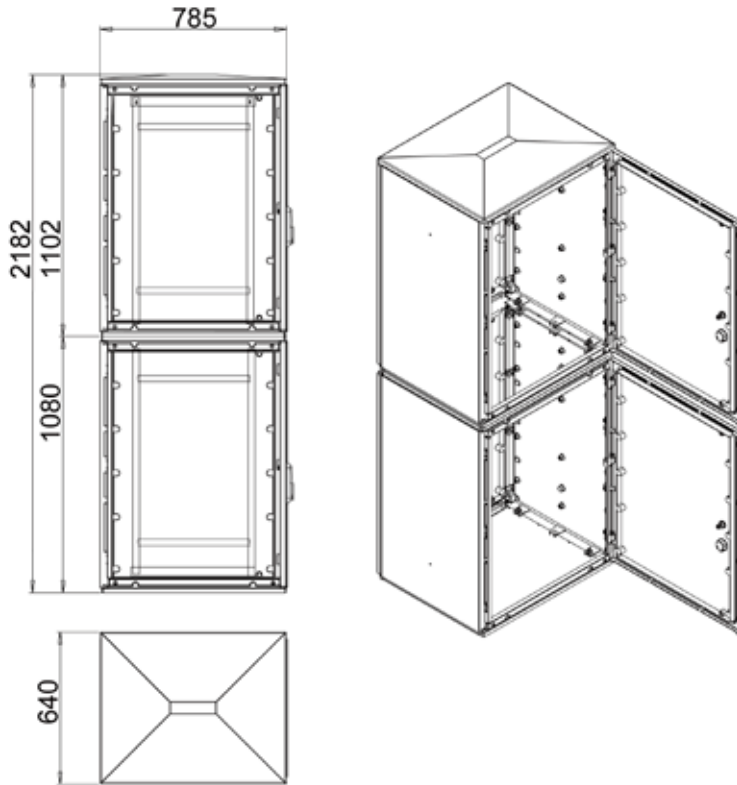

■ **Cabinet Size:**

785W x 2182H x 640D mm

■ **Protection level:**

IP65 according to IEC 529,
BS EN 60529:1992 Certified,
NEMA 4X and lower

■ **IP-66/65-55 & Lower:**

BS EN 60529:1992 Certified,
NEMA 4X and lower

Test	Norm	Unit	
Young's modulus	DIN EN 527-4	GPa	12
Tensile strength	DIN EN 527-4	MPa	62
Flex strength	ISO 14125	MPa	150
Flex modulus	ISO 14125	GPa	10
Impact strength	ISO 179	kJ/m ²	> 68
Volume resistivity	IEC 60093	Ohm/cm	1.00E+15
Surface resistivity	IEC 60093	Ohm	1.00E+13
Tracking index	IEC 60112	Stufe	CTI600
Dielectric strength	IEC 60243.1	kV/cm	240
Dielectric constant	IEC 60250		4
Dissipation factor	IEC 60250	Tan Delta	0.01
Water absorption	ISO 62	mg/4d	45
Surface resistance	IEC 60093	Ohm	>10 ¹²
Dielectric resistance	IEC 60243)	kV/mm	> 18
Stability by light	DIN EN ISO 877		7 – 8
Tropical and moisture resistance	IEC 60068-2-5 ed. 69		without any degradation Stability of shape
Stability of shape	ISO 75 (equiv. DIN 53462)		> 200°C
Temperature resistance continuously		°C	- 50 - + 150 Flame resistance
Flame resistance	UL 94 V0	mm	4

Scheme & Single diagram

Scheme Diagram

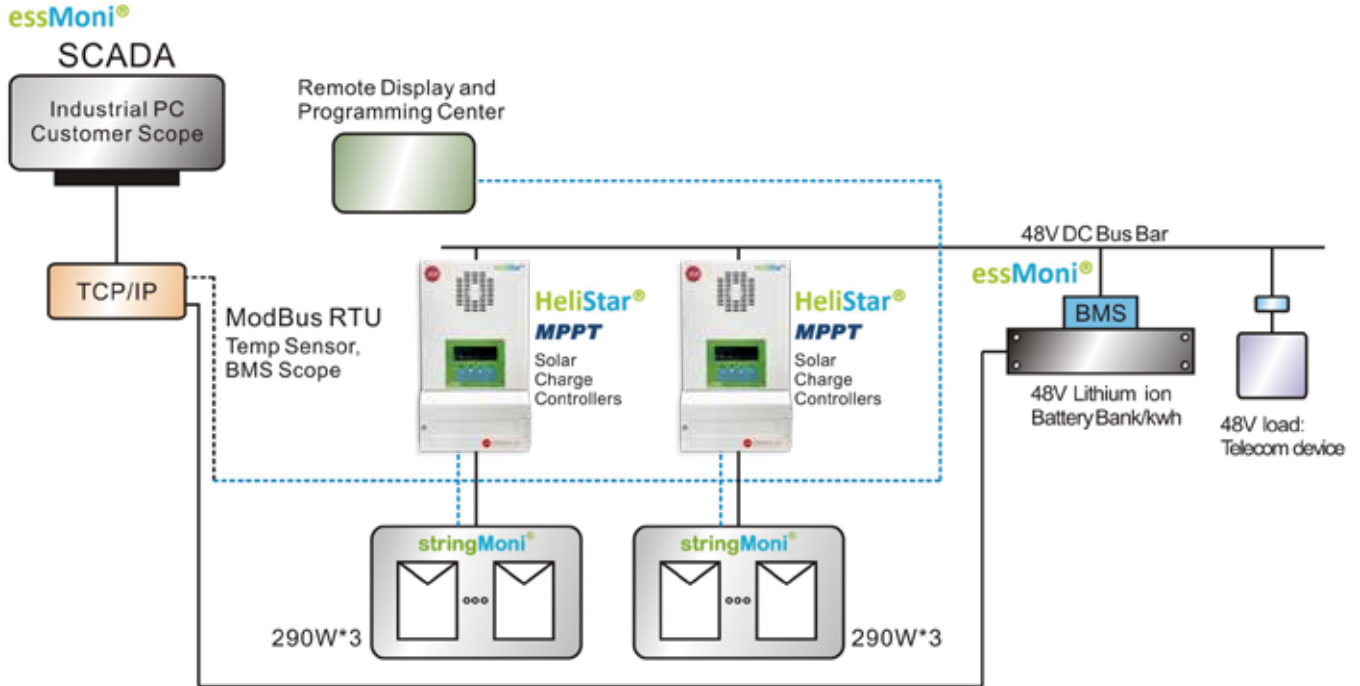

Single Diagram

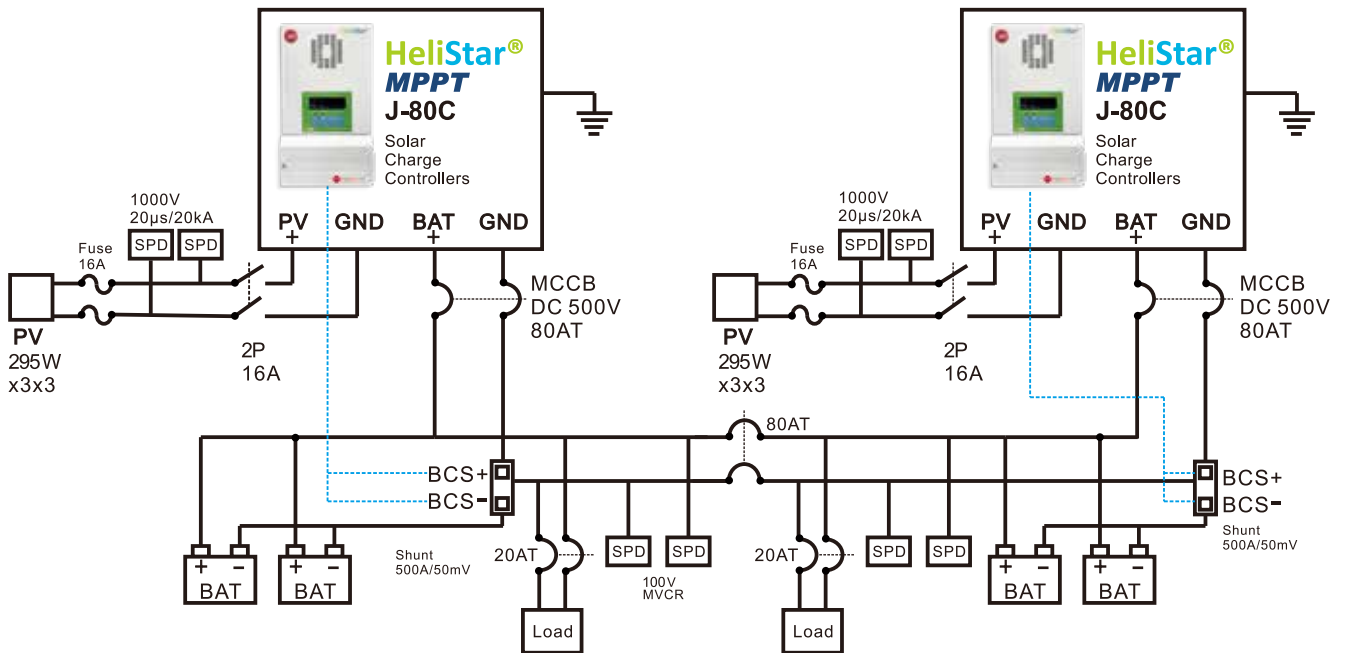

HeliStar[®] MPPT Solar Charge Controller

Specification



Solar Charge Controller
J-50C / J-80C / J-80CX / J160CX

Model No.	J-50C MPPT	J-80C MPPT	J-80CX MPPT	J-160CX MPPT
Maximum output current (Continuous at up 50°C ambient temperature)	50 Amps	80 Amps	80 Amps	160 Amps
Battery Voltages	12,24,36,48 VDC Normal			
Max PV Input Current	40 Amps	70 Amps	70 Amps	140 Amps
Input Voltage Range	16~112VDC Operating		16~192VDC Operating	
	140VDC Maximum Open Circuit Voltage		240VDC Maximum Open Circuit Voltage	
Max PV Array Power	3250 Watts (Maximum when equalizing a 48V battery to 64V at 50 Amps)	5200 Watts (Maximum when equalizing a 48V battery to 64V at 80 Amps)	5200 Watts (Maximum when equalizing a 48V battery to 64V at 80 Amps)	10400 Watts (Maximum when equalizing a 48V battery to 64V at 160 Amps)
Charge Regulation Modes	Bulk, Absorption, Float, Auto/ Manual Equalization			
Battery Temperature Compensation	5.0 mV per °C, per 2 volt cell			
DC to DC Conversion Capability	12V Battery: 16~112VDC		12V Battery: 16~192VDC	
	24V Battery: 32~112VDC		24V Battery: 32~192VDC	
	36V Battery: 48~112VDC		36V Battery: 48~192VDC	
	48V Battery: 64~112VDC		48V Battery: 64~192VDC	
Display Status	Built-in 2-line, 20-character LCD with backlight LCD status screen displays input voltage and current, output voltage and current, charge-mode, Battery SOC			
Data Logging	Logs energy harvested for 90 days, LCD displays WH, KWH, AH			
Energy Monitor	LCD shows SOC, AH, WH, and present charge or discharge current. A 50mV/ 500Amp shunt is required to use			
Auxiliary Relays	Two independent relays with from A (SPST) contacts for control of external devices. Contact rating is 3 Amps, 50VDC			
Operation Temperature	Full Power Output to +50°C ambient			
Standby Power	< 2 Watts			< 4 Watts
Dimension	267.6 x 196 x 147 mm	414.8 x 225 x 147 mm	414.8 x 225 x 147 mm	498 x 392.6 x 147 mm
Weight	4.3 Kgs	7.1 Kgs	7.1 Kgs	17 Kgs

HeliStar[®] MPPT Control MENU

Contents Tree

		GROUP	CONSTANTS
MENU	Operation		U-00 IN =xxx.xV xxx.xAmps OUT =xxx.xV xxx.xAmps
			U-01 Input Voltage
			U-02 Input Current
			U-03 Output Voltage
			U-04 Output Current
			U-05 EnergyHarvestToday 1
			U-07 EnergyHarvestToday 2
			U-08 Stage of Charger
			U-09 HeliStar Date
			U-10 HeliStar Time
			U-11 HeliStar Temperature
			U-12 Battery SOC
			U-13 Battery Current
			U-14 Battery Amp Hours
			U-15 Battery Temperature
			U-16 Parallel COMM Status
			U-17 Serial Number
Initialize		A-01 Access Level	
		A-02 Init Parameters	
		A-03 Password 1	
		A-04 Password 2	
Programming	B Battery Setup	B-01 Set Battery Voltage	
		B-02 Set Battery Type	
		B-04 Set Battery Capacity	
		B-05 BAT. MAX Charge Amps	
		B-06 Set Absorption Voltage	
		B-07 Set Absorption Time	
		B-08 Set Float Voltage	
		B-09 Set Equalize Voltage	
		B-10 Set MAX EQU. Time	
		B-11 Set Days Between EQU	
		B-12 Manual Equalize	
		C MPPT Setup	C-01 Set MPPT Type
C-02 Set Scan Frequency			
C-03 Set Percentage VOC			
C-04 Percentage Every Time			
C-05 Set Hold Input Volts			
D Auxiliary Relay 1	D-01 Set Aux Relay 1 Mode		
	D-02 Aux RY1 ON Condition		
	D-03 AuxRY1 OFF Condition		
	D-04 Aux RY1 MIN. ON time		
E Auxiliary Relay 2	E-01 Set Aux Relay 2 Mode		
	E-02 Aux RY2 ON Condition		
	E-03 AuxRY2 OFF Condition		
	E-04 Aux RY2 MIN. ON time		
F Parallel Setup	F-01 HeliStar Parallel MODE		
	F-02 HeliStar Parallel Addr		
O Operator	O-01 Set Clock Mode		
	O-02 Set HeliStar Time		
	O-03 Set HeliStar Date		
	O-04 Model Number		
	O-05 Turn OFF Backlight T		
	O-06 FAN Test		
	O-07 Software Version		
	O-08 ***Bootloader***		
Data Log	G-01 EnergyHarvestToday 1		
	G-02 EnergyHarvestToday 2		
	G-03 Set Day LOG # (1-90)		
	G-04 Day LOG # : kWhr		
	G-05 Day LOG # @ FLOAT		
	G-06 Average Last Days		
	G-07 Last Days: kWhr		
	G-08 Last Days @ FLOAT		
	G-09 Clear Energy Harvest		

essMoni[®] Monitoring

Monitoring System



Solar Panel Input String Monitoring



Detect INV DC IN DCV DCA
DC OUT DCV DCA

INV monitoring integrated with stringMoni[®]



Error Code



Charge Controller



It can detect DC IN DCA DCV
 Control battery charge and discharge

BMS integrated with essMoni[®]



ModBus access

- | | |
|---------------------------------|----------------------------------|
| 1.Input Voltage (PV Input) | 11.MPPT Temperature |
| 2.Input Current (PV Input) | 12.NET Mode |
| 3.Output Voltage | 13.Battery SOC |
| 4.Output Current | 14.BatteryVoltage |
| 5.Today Amp Hour (Low 16bits) | 15.Battery Current |
| 6.Today Amp Hour (High 16bits) | 16.Battery Amp Hour |
| 7.Today Watt Hour (Low 16bits) | 17.Battery Temperature |
| 8.Today Watt Hour (High 16bits) | 18.Shunt Connect Status |
| 9.Today FloatTime | 19.Voltage sensor Connect Status |
| 10.Real time Charge State | |

TCP/IP connection for different country, please specify

SNMP NAT VPN Firewall
 Wireless 4G network card

stringMoni[®]

太陽能發電 智慧監測系統 雲端網頁管理

PV String Monitoring System & Web-server

太陽光發電スマート遠隔監視システム・ウェブサーバ

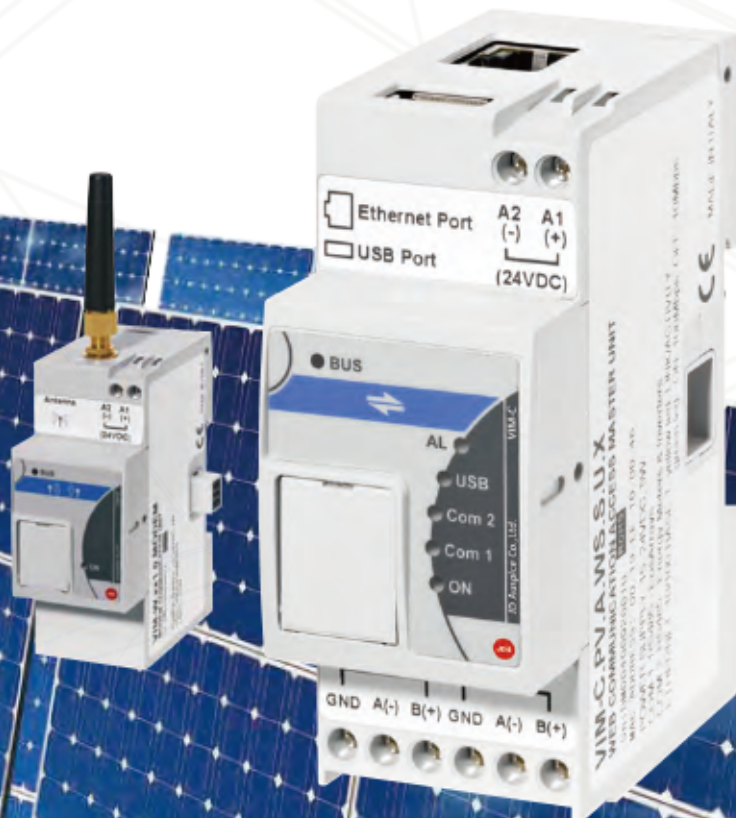
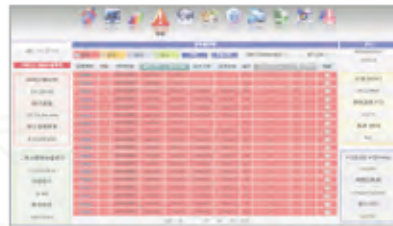

屋頂型、小/中/大型 太陽能系統專用網頁伺服器
For the Rooftop, big to small PV plants Web Server solution
屋上型、小/中/大型、太陽光發電システム遠隔監視ウェブサーバ



内建免費OPC伺服軟體、整合SCADA驅動程式、提供所有SCADA系統整合廠商監測資料訊息平台。
The new freeware OPC server is available for driver-less integration to SCADA
最新無料OPC通信用サーバが内蔵され、全てのSCADAドライバ、システムに統合対応でき、監視データを簡単に入手。

A VIM-C 產品規格介紹 VIM-C Functions and features, VIM-C 機能と特徴

- ◎ 雲端管理
Cloud management
クラウド管理
- ◎ 可擴充100台VIM-C, 1KW~1.4MW
Each VIM-C can manage up to 100 VIM-C 1KW-1.4MW
VIM-C100台まで接続可能、1KW-1.4MWに対応
- ◎ 監測可透過有線或無線
Integrated Wired or Wireless Web-Service solution
有線或るは無線で監視可能
- ◎ 監測模組選擇彈性
Comprehensive monitoring Solution
監視ソリューションの多様な選択肢
- ◎ a. AC端+INVERTER+DC串列+自動控制設定模組+環境量測模組+防盜裝置
a.AC+ INVERTER + DC strings + VIM-O (I/O unit)+VIM-P+VIM-AT
a.交流+パワーコンディショナー+直流ストリング+自動制御入出力ユニット+環境計測ユニット+防犯装置
- ◎ b. AC端+INVERTER+環境量測模組
b.AC+INVERTER + environment variable unit
b.交流+パワーコンディショナー+環境計測ユニット
- ◎ 與30廠牌以上的inverter內建通訊協定
Compatibility to more than 30 different inverter
30種類以上のパワーコンディショナーの通信プロトコルに対応。
- ◎ 同Micro PC with Web server, Web service功能
Micro PC with Web server and Web service capability
マイクロPCウェブサーバ、ウェブサービスとして兼用。
- ◎ 顯示DC端串列資料: 伏特、安培、千瓦、千瓦時
DC part managed information: V, A, kW, kWh
DC ストリング稼働状態を表示: 電圧、電流、電力、電力量の数値
- ◎ 顯示AC端串列資料: 伏特、安培、千瓦、千瓦時
AC part managed information: V, A, kW, kWh from energy meter
AC ストリング稼働状態を表示: 電圧、電流、電力、電力量の数値



更多產品及規格請來電洽詢 For further information, please contact us as indicated below. そのほかの製品及び仕様に関するお問い合わせは下記までご連絡下さい。

屋頂型、小/中/大型 太陽能系統專用網頁伺服器
For the Rooftop, big to small PV plants Web Server solution
屋上型、小/中/大型、太陽光發電システム遠隔監視ウェブサーバ



内建免費OPC伺服軟體、整合SCADA驅動程式、提供所有SCADA系統整合廠商監測資料訊息平台。
The new freeware OPC server is available for driver-less integration to SCADA
最新無料OPC通信用サーバが内蔵され、全てのSCADAドライバ、システムに統合対応でき、監視データを簡単に入手。

A

VIM-C 產品規格介紹

VIM-C Functions and features · VIM-C 機能と特徴

- ◎ 顯示環境測量值: 日照, 模組溫度, 大氣溫度, 風速
Environment variables: sun-irradiation, cell-temperature, air-temperature and wind speed
環境データ表示: 日射度、セルの温度、大気温度、風速
- ◎ 可透過e-mail及SMS自動管理警示控制
Alarms control with automatic e-mailing and SMS management
異常通知のSMS(メール)送信を設定可能
- ◎ 變流器警示及錯誤功能
Inverters: Vac(Vdc with VIM-S), ac(Adc with VIM-S), kWac(kWdc with VIM-S) and alarm and error messages
パワーコンディショナー直交流電力交換時: Vac(Vdc with VIM-S), ac(Adc with VIM-S), kWac (kWdc with VIM-S)の異常エラーメッセージ表示と通知機能付き。
- ◎ 串列・系統組件(BOS), 效率比PR(KWH/KWP)三種效率的計算與控制
Efficiency calculation and control on three different levels: String, BOS and PR (kWh/kWp performance ratio)
ストリング、出力向上システム部品(BOS)、性能比(kWh/kWp)の効率計算及び管理機能付き
- ◎ CSV格式輸出
CSV All data exports on CSV format
CSV形式のデータに変換可能
- ◎ 使用8GB SD記憶卡(選購品), 可儲存20年資料
Data storage up to 20 years in a up to 8GB micro SD memory (option)
SDメモリーカード8GBを搭載可能、最大20年間の計測データを保存可能。(オプション品)
- ◎ 輸出入埠RS-485*2、USB2.0*2
Communication ports RS-485x2, USB 2.0 x 2
通信ポート:RS-485x2, USB 2.0 x 2
- ◎ 乙太網路*1 電源供應12~28Vdc
Ethernet port x1, power supply 12 to 28Vdc
イーサネットポートx 1, 12-28Vdcに対応
- ◎ 軌道安裝,保護等級(正面):IP40
2-DIN modules, Protection degree (front): IP40
DINモジュール(2本)、表面部保護レベル:IP40



更多產品及規格請來電洽詢 For further information, please contact us as indicated below. そのほかの製品及び仕様に関するお問い合わせは下記までご連絡下さい。

B 單一VIM-C可擴充每串監測stringMoni®監測模組數量

Each VIM-C can manage up to: • VIM-C 1ユニットあたり搭載可能なソリューション:

- ☑ 變流器x64台
Inverter x 64 pcs
パワーコンディショナーx64台まで
- ☑ 電表x64台
Energy meter x 64 pcs
電力計x64台まで
- ☑ VIM-M資料傳輸主模組x14台
VIM-M Master module and Data logger x 14 pcs
VIM-Mマスターモジュール及&データ収集ユニットx14台まで
- ☑ VIM-S串列監測模組x15台
VIM-S String measuring unit x 15 pcs
VIM-Sストリング計測ユニットx15台まで
- ☑ VIM-P溫度日照風速量測模組x1台
VIM-P Environment variable unit x 1 pc
VIM-P温度、日照、風速計測ユニットx 1台
- ☑ VIM-O自動控制設定模組x1台
VIM-O Inputs/Outputs unit x 1 pc
VIM-O自動制御入出力ユニットx 1台
- ☑ VIM-1隔離卡
VIM-1 Isolation enhancement unit x 1 pc
VIM-1アイソレーションユニットx 1台



擴充示意圖例 Exceeding map 擴充例

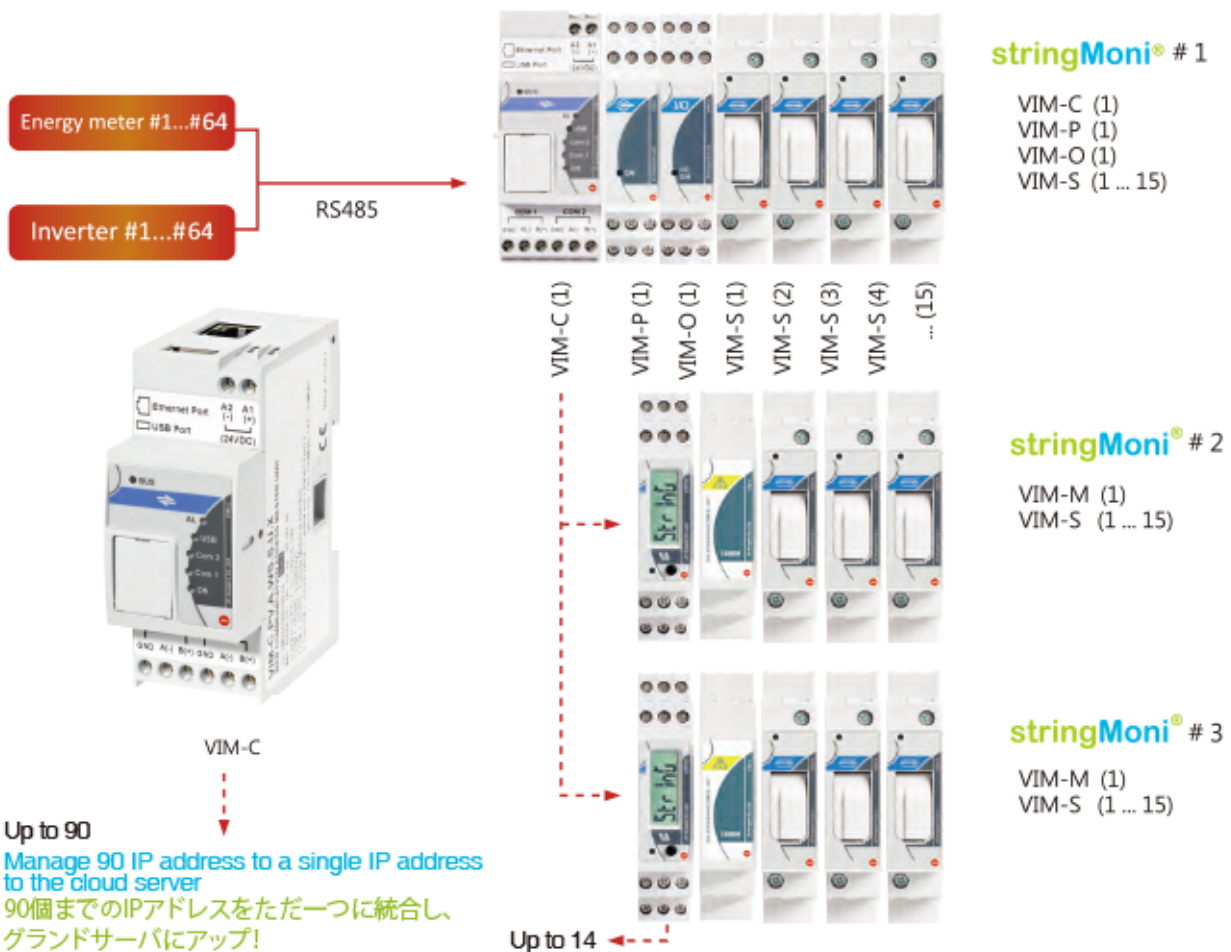

更多產品及規格請來電洽詢 For further information, please contact us as indicated below. そのほかの製品及び仕様に関するお問い合わせは下記までご連絡下さい。

Battery Bank

Specification

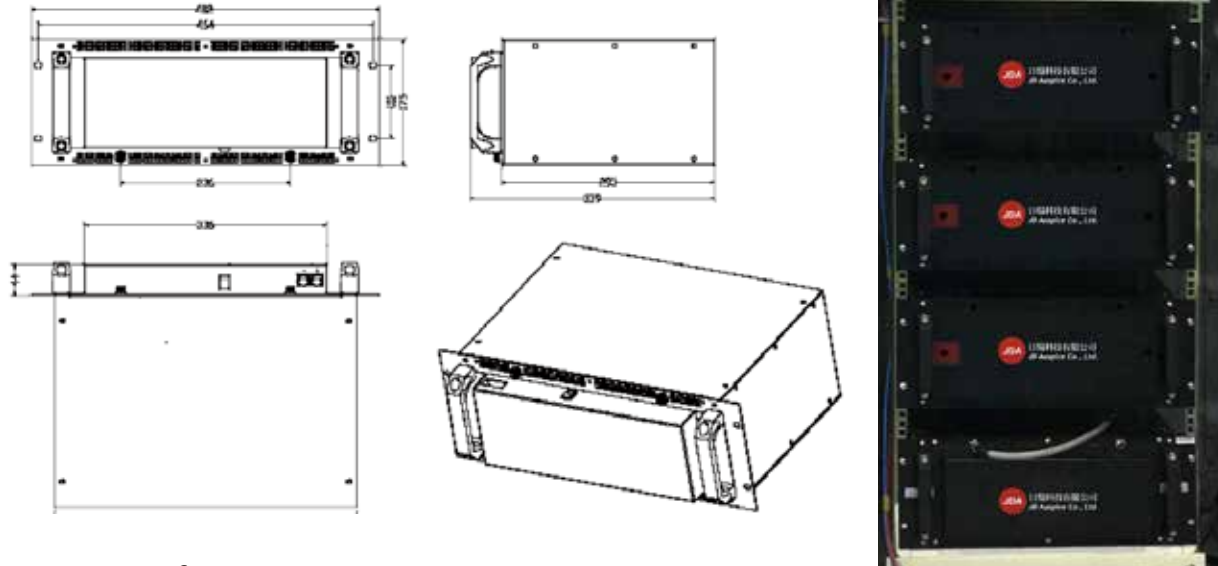

Battery Specification

Model	JMP-2
Energy [kWh]	4.9
Nominal Voltage [V]	51.1
Voltage Range [V]	39.2~58.8
Nominal Capacity [Ah]	96
Max Discharge Current [Amp]	48
Discharge Current [Amp]	48
Charge Voltage [V] Max	58.8
Cell Type	Pouch
Chemistry	LiCoNiMnO
Dimensions (LWH) [mm/inch]	482(L) x 175(W) x 339(H)mm (±3mm)
Weight [kg]	36.3

Performance

Cycle (0.2 charge and 0.2C discharge)	>4000 cycle 85%DOD,Temp 25~35°C
End of Life	80% SOC of 4000 cycle 85% DOD
Self-Discharge	TBD
Round Trip Efficiency	98.50%

Operation Environments

Operating Temperature	0~50°C
Storage Temperature	-20~55°C
Humidity	RH45~85%

Front Panel

Status Indicators	NA
SOC / ALM / RUN	NA
Protocol	RS485
Communication Ports	WP-04GF2-44 Waterproof Connector 4PIN(F)
Communication Parallel	Up to 6 trays

Certification	IEC62133
----------------------	----------

DC SWITCH

Data Sheet

XBE+0210/2

Certified for IEC 60947 1&3
DC-PV1 and CCC (CQC)

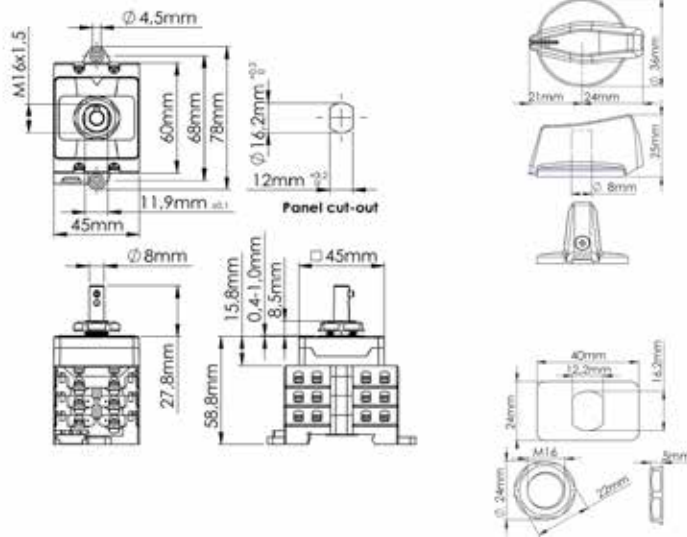

The tolerances for the Santon datasheet are according to ISO 1101, ISO 8015, ISO 2768 1 class m, unless stated otherwise.

Technical data	Symbol	Rated:	I	II	III	IV	Unit	
Rated operational voltage	Ue		1100	1000	800	500	V dc	
Rated operational current	Ie		10	16	25	50	A dc	
Required fine wire cross-section (minimal)*:			2,5	2,5	4	10	mm ²	
*IEC60947-1, table 9								
Number of DC poles						2		
Utilization category DC						DC-PV1		
Pollution degree						2		
IP rating terminals						IP20		
Tightening torque terminal screws M4 (min. - max.)					1,5 - 1,7		Nm	
Method of mounting								
IP rating of the shaft in case of single hole mounting						IP65		
Tightening torque panel mounting nut (min. - max.)					2,0 - 2,5		Nm	
Panel thickness between					1 - 4		mm	
Positions						12 (OFF) and 3 o'clock (ON)		
Actuator						Standard A knob with long screw to fix in shaft		
Method of operation						Independent manual operation		
Actuator operation force (max.)						1,4	Nm	
Tightening torque M3 screw in the actuator (min. - max.)					0,50 - 0,70		Nm	
Rated impulse withstand voltage	Uimp					8	kV	
Insulation voltage	Ui					1100	V	
Rated thermal current uninterrupted duty	Iu					50	A	
Rated short-time withstand current (1s)	Icw					700	A	
Rated short-circuit making capacity	Icm					1	kA	
Rated conditional short-circuit current	Isc					5	kA	
Minimum required dimensions of enclosures L x W x D* (space envelope)								
			124	x	47	x	50	mm
* see the drawing for the height of the switch. The number of layers N is:								
						2		
Weight						ca. 149	g	
Allowed ambient temperature (min. - max.)	Tambient					-40 - 70	°C	
Allowed storage temperature (min. - max.)	Tstorage					-40 - 85	°C	
Relative humidity (max.), without condensation at 20 °C	RH					90	%	

Terminals Scheme					
Layer No.	Front Side	Symbol	Rear Side	Positions	
	Left		Left	Right	1 2 3 4
9					
8					
7					
6					
5					
4					
3	-1		-1	I	0
2	+1		+1	I	0
1		Empty			

(I = Contact is closed, O = Contact is open)

Mounting instructions

In the application all ratings according to the datasheet have to be respected. After mounting, the wiring must be checked and the switch must operate smoothly. When building the switch in an enclosure, the space envelope must be respected according to the applicable standards.

Maintenance

The X type switches are designed for a very long life but it is advised to do some simple yearly maintenance.
- Check the installation for signs of overload or overheating. The terminals may not exceed the limit of 85°C under full load.
- By operating the switch a few times (5x) the contacts will clean themselves and the switch will have a longer life.

Connection

The terminals, can take copper wires up to 6 mm². The recommended Spade Tongue Terminals may have a maximum width of 9 mm (see table for recommendations)

*1 16mm² only with fine stranded wire (or two times 6mm²)

*2 Optional: A yellow finger safe sleeve for the Spade Tongue Terminal (Santon 52A1256.35) can be ordered under item number 52A1564.00

Recommend Manufacturer	Type number	Wire size (AWG)	Wire size (mm ²)	Color
JST	FVD2-YS4A	AWG 16 – AWG 14	1,0 – 2,5 mm ²	Blue
TE connectivity	C-165012	AWG 16 – AWG 14	1,0 – 2,5 mm ²	Blue
Vogt	3635c	AWG 16 – AWG 14	1,5 – 2,5 mm ²	Blue
TE connectivity	C-165015	AWG 12 - AWG 10	3,0 - 6,0 mm ²	Yellow
Vogt	3652c / 3653c	AWG 12 - AWG 10	3,0 - 6,0 mm ²	Yellow
Santon (JST)	52A1256.35	AWG 8 - AWG 10	10,5mm ² -16mm ² *1	*2



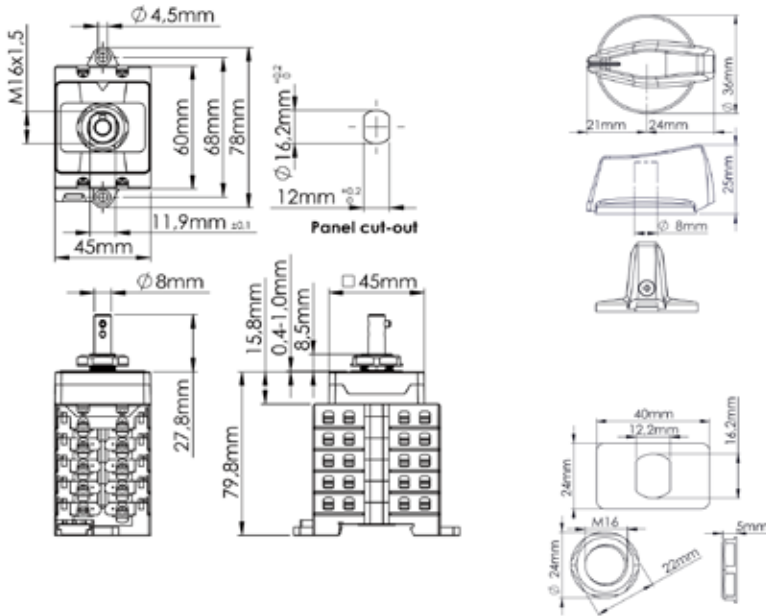

DC SWITCH

Data Sheet **XBE+0410/2** Certified for IEC 60947 1&3 DC-PV1 and CCC (CQC) 



The tolerances for the Santon datasheet are according to ISO 1101, ISO 8015, ISO 2768 1 class m, unless stated otherwise.

Technical data	Symbol	Ratings:	I	II	III	IV	Unit	
Rated operational voltage	Ue		1100	1000	800	500	V dc	
Rated operational current	Ie		10	16	25	50	A dc	
Required fine wire cross-section (minimal)*:			2,5	2,5	4	10	mm ²	
*IEC60947-1, table 9								
Number of DC poles						4		
Utilization category DC						DC-PV1		
Pollution degree						2		
IP rating terminals						IP20		
Tightening torque terminal screws M4 (min. - max.)					1,5	1,7	Nm	
Method of mounting								
IP rating of the shaft in case of single hole mounting						IP65		
Tightening torque panel mounting nut (min. - max.)					2,0	2,5	Nm	
Panel thickness between					1	4	mm	
Positions			12 (OFF) and 3 o'clock (ON)					
Actuator			Standard A knob with long screw to fix in shaft					
Method of operation			Independent manual operation					
Actuator operation force (max.)						1,4	Nm	
Tightening torque M3 screw in the actuator (min. - max.)					0,50	0,70	Nm	
Rated impulse withstand voltage								
	Uimp					8	kV	
Insulation voltage								
	Ui					1100	V	
Rated thermal current uninterrupted duty								
	Iu					50	A	
Rated short-time withstand current (1s)								
	Icw					700	A	
Rated short-circuit making capacity								
	Icm					1	kA	
Rated conditional short-circuit current								
	Isc					5	kA	
Minimum required dimensions of enclosures L x W x D* {space envelope}								
			124	x	47	x	71	mm
* see the drawing for the height of the switch. The number of layers N is:								
						4		
Weight								
						ca. 211	g	
Allowed ambient temperature (min. - max.)								
	Tambient		-40	-	70		°C	
Allowed storage temperature (min. - max.)								
	Tstorage		-40	-	85		°C	
Relative humidity (max.), without condensation at 20°C								
	RH					90	%	

Terminals Scheme									
Layer No.	Front Side		Symbol	Rear Side		Positions			
	Left	Right		Left	Right	1	2	3	4
9									
8									
7									
6									
5	+2			+2		I			0
4		-2			-2		I		0
3		-1			-1		I		0
2		+1			+1		I		0
1			Empty						

(I = Contact is closed, O = Contact is open)

Mounting instructions

In the application all ratings according to the datasheet have to be respected. After mounting, the wiring must be checked and the switch must operate smoothly. When building the switch in an enclosure, the space envelope must be respected according to the applicable standards.

Maintenance

The X type switches are designed for a very long life but it is advised to do some simple yearly maintenance.
- Check the installation for signs of overload or overheating. The terminals may not exceed the limit of 85°C under full load.
- By operating the switch a few times (5x) the contacts will clean themselves and the switch will have a longer life.

Connection

The terminals, can take copper wires up to 6 mm². The recommended Spade Tongue Terminals may have a maximum width of 9 mm (see table for recommendations)

Recommend Manufacturer	Type number	Wire size (AWG)	Wire size (mm ²)	Color
JST	FVD2-YS4A	AWG 16 – AWG 14	1,0 – 2,5 mm ²	Blue
TE connectivity	C-165012	AWG 16 – AWG 14	1,0 – 2,5 mm ²	Blue
Vogt	3635c	AWG 16 – AWG 14	1,5 – 2,5 mm ²	Blue
TE connectivity	C-165015	AWG 12 - AWG 10	3,0 - 6,0 mm ²	Yellow
Vogt	3652c / 3653c	AWG 12 - AWG 10	3,0 - 6,0 mm ²	Yellow
Santon (JST)	52A1256.35	AWG 8 - AWG 10	10,5mm ² -16mm ² *1	*2

*1 16mm² only with fine stranded wire (or two times 6mm²)

*2 Optional: A yellow finger safe sleeve for the Spade Tongue Terminal (Santon 52A1256.35) can be ordered under item number 52A1564.00

DC SWITCH

Data Sheet

XBE+0610/2

Certified for IEC 60947 1&3
DC-PV1 and CCC (CQC)

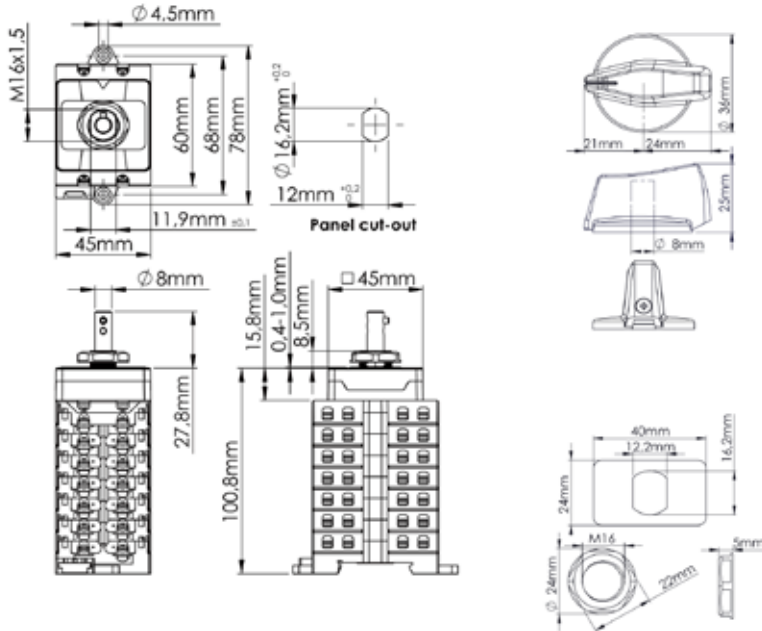

The tolerances for the Santon datasheet are according to ISO 1101, ISO 8015, ISO 2768 1 class m, unless stated otherwise.

Technical data	Symbol	Ratings:	I	II	III	IV	Unit	
Rated operational voltage	Ue		1100	1000	800	500	V dc	
Rated operational current	Ie		10	16	25	50	A dc	
Required fine wire cross-section (minimal)*:			2,5	2,5	4	10	mm ²	
*IEC60947-1, table 9								
Number of DC poles						6		
Utilization category DC						DC-PV1		
Pollution degree						2		
IP rating terminals						IP20		
Tightening torque terminal screws M4 (min. - max.)					1,5	1,7	Nm	
Method of mounting								
IP rating of the shaft in case of single hole mounting						IP65		
Tightening torque panel mounting nut (min. - max.)					2,0	2,5	Nm	
Panel thickness between					1	4	mm	
Positions			12 (OFF) and 3 o'clock (ON)					
Actuator			Standard A knob with long screw to fix in shaft					
Method of operation			Independent manual operation					
Actuator operation force (max.)						1,4	Nm	
Tightening torque M3 screw in the actuator (min. - max.)					0,50	0,70	Nm	
Electrical ratings								
Rated impulse withstand voltage	Uimp					8	kV	
Insulation voltage	Ui					1100	V	
Rated thermal current uninterrupted duty	Iu					50	A	
Rated short-time withstand current (1s)	Icw					700	A	
Rated short-circuit making capacity	Icm					1	kA	
Rated conditional short-circuit current	Isc					5	kA	
Dimensions								
Minimum required dimensions of enclosures L x W x D* (space envelope)			124	x	47	x	92	mm
* see the drawing for the height of the switch. The number of layers N is:								
						6		
Weight						ca. 274	g	
Allowed ambient temperature (min. - max.)	Tambient				-40	-	70	°C
Allowed storage temperature (min. - max.)	Tstorage				-40	-	85	°C
Relative humidity (max.), without condensation at 20°C	RH						90	%

Terminals Scheme							
Layer No.	Front Side Left	Front Side Right	Symbol	Rear Side Left	Rear Side Right	Positions 1	Positions 2 3 4
9							
8							
7	-3			-3		I	0
6		+3			+3	I	0
5	+2			+2		I	0
4		-2			-2	I	0
3	-1			-1		I	0
2		+1			+1	I	0
1			Empty				

(I = Contact is closed, O = Contact is open)

Mounting instructions

In the application all ratings according to the datasheet have to be respected. After mounting, the wiring must be checked and the switch must operate smoothly. When building the switch in an enclosure, the space envelope must be respected according to the applicable standards.

Maintenance

The X type switches are designed for a very long life but it is advised to do some simple yearly maintenance.

- Check the installation for signs of overload or overheating. The terminals may not exceed the limit of 85°C under full load.

- By operating the switch a few times (5x) the contacts will clean themselves and the switch will have a longer life.

Connection

The terminals, can take copper wires up to 6 mm².

The recommended Spade Tongue Terminals may have a maximum width of 9 mm (see table for recommendations)

*1 16mm² only with fine stranded wire (or two times 6mm²)

*2 Optional: A yellow finger safe sleeve for the Spade Tongue Terminal (Santon 52A1256.35) can be ordered under item number 52A1564.00

Recommend Manufacturer	Type number	Wire size (AWG)	Wire size (mm ²)	Color
JST	FVD2-YS4A	AWG 16 – AWG 14	1,0 – 2,5 mm ²	Blue
TE connectivity	C-165012	AWG 16 – AWG 14	1,0 – 2,5 mm ²	Blue
Vogt	3635c	AWG 16 – AWG 14	1,5 – 2,5 mm ²	Blue
TE connectivity	C-165015	AWG 12 - AWG 10	3,0 - 6,0 mm ²	Yellow
Vogt	3652c / 3653c	AWG 12 - AWG 10	3,0 - 6,0 mm ²	Yellow
Santon (JST)	52A1256.35	AWG 8 - AWG 10	10,5mm ² -16mm ² *1	*2

DC SWITCH

Data Sheet

XBE+0810/2

Certified for IEC 60947 1&3
DC21B and CCC (CQC)

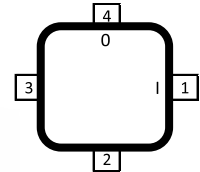
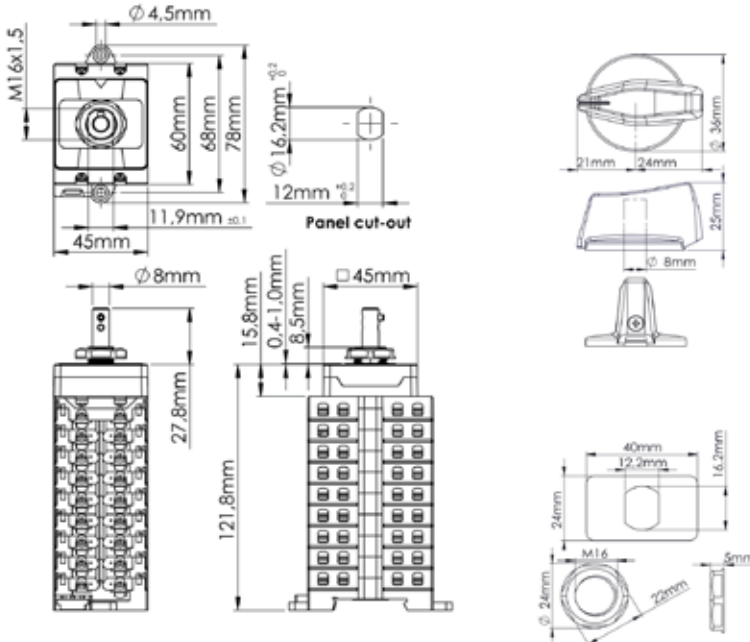

The tolerances for the Santon datasheet are according to ISO 1101, ISO 8015, ISO 2768 1 class m, unless stated otherwise.

Technical data	Symbol	Rated	I	II	III	IV	Unit
Rated operational voltage	Ue		1100	1000	800	500	V dc
Rated operational current	Ie		10	16	25	50	A dc
Required fine wire cross-section (minimal)*:			2,5	2,5	4	10	mm ²
*IEC60947-1, table 9							
Number of DC poles						8	
Utilization category DC						DC-PV1	
Pollution degree						2	
IP rating terminals						IP20	
Tightening torque terminal screws M4 (min. - max.)				1,5	-	1,7	Nm
Method of mounting							
IP rating of the shaft in case of single hole mounting						IP65	
Tightening torque panel mounting nut (min. - max.)				2,0	-	2,5	Nm
Panel thickness between					1	-	4 mm
Positions			12 (OFF) and 3 o'clock (ON)				
Actuator			Standard A knob with long screw to fix in shaft				
Method of operation			Independent manual operation				
Actuator operation force (max.)						1,4	Nm
Tightening torque M3 screw in the actuator (min. - max.)				0,50	-	0,70	Nm
Rated impulse withstand voltage							
		Uimp				8	kV
Insulation voltage							
		Ui				1100	V
Rated thermal current uninterrupted duty							
		Iu				50	A
Rated short-time withstand current (1s)							
		Icw				700	A
Rated short-circuit making capacity							
		Icm				1	kA
Rated conditional short-circuit current							
		Isc				5	kA
Minimum required dimensions of enclosures L x W x D* {space envelope}							
			124	x	47	x	92 mm
* see the drawing for the height of the switch. The number of layers N is:							
						6	
Weight							
						ca. 274	g
Allowed ambient temperature (min. - max.)							
		Tambient		-40	-	70	°C
Allowed storage temperature (min. - max.)							
		Tstorage		-40	-	85	°C
Relative humidity (max.), without condensation at 20°C							
		RH				90	%

Terminals Scheme									
Layer No.	Front Side		Symbol	Rear Side		Positions			
	Left	Right		Left	Right	1	2	3	4
9	+4			+4		I			0
8		-4			-4	I			0
7	-3			-3		I			0
6		+3			+3	I			0
5	+2			+2		I			0
4		-2			-2	I			0
3	-1			-1		I			0
2		+1			+1	I			0
1			Empty						

(I = Contact is closed, O = Contact is open)

Mounting instructions

In the application all ratings according to the datasheet have to be respected. After mounting, the wiring must be checked and the switch must operate smoothly. When building the switch in an enclosure, the space envelope must be respected according to the applicable standards.

Maintenance

The X type switches are designed for a very long life but it is advised to do some simple yearly maintenance.
- Check the installation for signs of overload or overheating. The terminals may not exceed the limit of 85°C under full load.
- By operating the switch a few times (5x) the contacts will clean themselves and the switch will have a longer life.

Connection

The terminals, can take copper wires up to 6 mm². The recommended Spade Tongue Terminals may have a maximum width of 9 mm (see table for recommendations)

*1 16mm² only with fine stranded wire (or two times 6mm²)

*2 Optional: A yellow finger safe sleeve for the Spade Tongue Terminal (Santon 52A1256.35) can be ordered under item number 52A1564.00

Recommend Manufacturer	Type number	Wire size (AWG)	Wire size (mm ²)	Color
JST	FVD2-YS4A	AWG 16 – AWG 14	1,0 – 2,5 mm ²	Blue
TE connectivity	C-165012	AWG 16 – AWG 14	1,0 – 2,5 mm ²	Blue
Vogt	3635c	AWG 16 – AWG 14	1,5 – 2,5 mm ²	Blue
TE connectivity	C-165015	AWG 12 - AWG 10	3,0 - 6,0 mm ²	Yellow
Vogt	3652c / 3653c	AWG 12 - AWG 10	3,0 - 6,0 mm ²	Yellow
Santon (JST)	52A1256.35	AWG 8 - AWG 10	10,5mm ² -16mm ² *1	*2

DC Molded Case Circuit Breaker (MCCB)

Specification



Main Technical Parameters

1) Electrical characteristics

- ▲ Rated insulation voltage U_i : 1000V
- ▲ Rated working voltage U_e : DC500V(2P); DC750V(3P); DC1000V(4P);
- ▲ Rated current of housing I_{nm} : 125A
- ▲ Rated limit short-circuit breaking current I_{cu} : 20kA
- ▲ Rated operating short-circuit breaking current I_{cs} : 20kA
- ▲ Rated operating current of auxiliary contact: 0.3A
- ▲ Conventional thermal current of auxiliary contact: 3A

2) Operating performance

- ▲ With Current: 5000times
- ▲ Without Current: 20000times

3) Mode of connection

- 2P: Wiring mode 2P;
- 3P: J0Wiring, NormalWiring;
- 4P: J0Wiring, J1 Wiring, J2Wiring ;

4) Connection capacity:

Rated current (A)	16 ~ 20	25	32	40 ~ 50	63	80	100	125 ~ 140	160	180 ~ 200 ~ 225	250
Wire cross-section area (mm ²)	2.5	4	6	10	16	25	35	50	70	95	120

Note: The products whose rated current is 100A or 125A need to use the connecting bars (see 3P product installation dimension), for standard wire terminal whose cross-sectional area is more than 35mm² is interference with the product terminal slot.

5. Normal Working Environment

- ▲ Altitude: ≤4000m (if the altitude is higher than 4000m, consider reducing the capacity, as shown in the Attached Sheet of Derating Factor).
- ▲ Operating ambient temperature: -35°C~+70°C (if the temperature is higher than 50°C, consider reducing the capacity, as shown in the Attached Sheet of Derating Factor; negotiate with the factory in case the temperature is lower than -35°C).
- ▲ The relative humidity at an ambient temperature of +40°C should not exceed 50%. A higher relative humidity is allowed at a lower temperature. For example, the relative humidity at 20°C can reach 90%. For frost due to temperature change, the corresponding measures should be taken.
- ▲ Pollution level: 3.
- ▲ The product can withstand the effects of wet air, salt mist and oil mist.
- ▲ The maximum gradient is 22.5°.
- ▲ The product can be disposed in places that are free from explosive media, media corrosive to metal, insulation damaging gas, and conductive dust.
- ▲ The product should be installed free from snow and rain.
- ▲ In case of stricter user conditions than the above description, negotiate with the manufacturer.

DC MCB

Specification

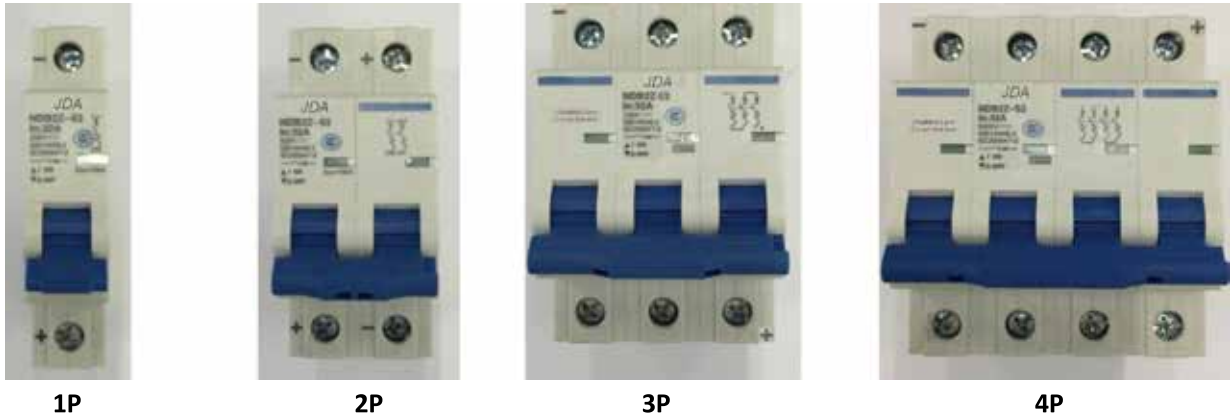

1 \ Applicable scope and purpose

- Short-circuit protection
- Over-load protection
- Control
- Isolation
- DC system protection

NDB2Z-63 dedicated to the low voltage power distribution system of industrial, buildings, energy communications and infrastructure.

2 \ Model and implication

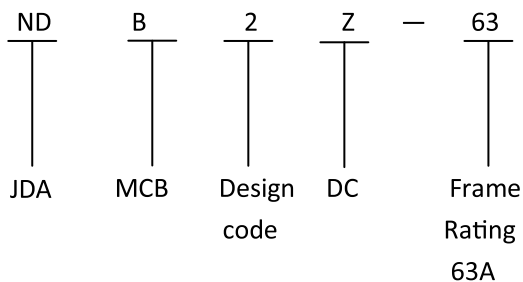

3 \ Main technical specification

- Electrical parameters
 - Rated voltage : 1P : DC125/220/250V , 2P : DC250/440/500 V, 3P : DC750V, 4P : DC1000V
 - Rated current : 1A, 2A,3A,4A, 5A ,6A, 7A,8A,10A, 12A, 13A,15A,16A, 20A,25A,30A,32A,40A,50A,60A,63A
 - Rated ultimate short-circuit breaking capacity : DC125 /220 /250V (1P) , DC250/440/500 V : 10kA DC750V/ DC1000V : 5 kA
 - Impulse withstand test voltages : 6kV
 - Mechanical & electrical life : 20000 times

Surge Protective Devices

Specification

PV40/100-MVCR

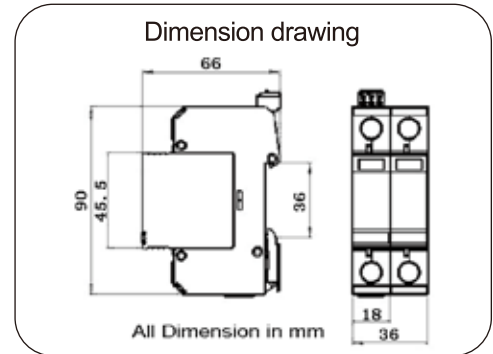
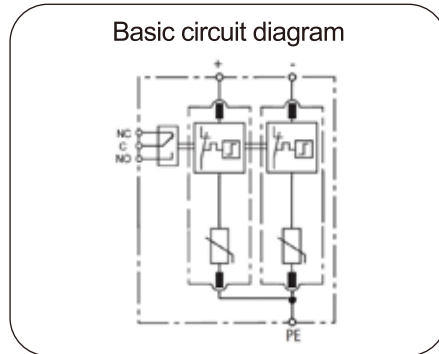

Type 2 surge arrester designed for low voltage DC system against surges at the boundaries from lightning protection zone 0B-2 and higher.

- ⊙ In accordance with EN50539, IEC61643-11 and UL1449-4th
- ⊙ DC SPD for common mode protection
- ⊙ Pluggable module design, easy replacement
- ⊙ High discharge current 40kA 8/20
- ⊙ Reliable supervision due to disconnection device
- ⊙ Fault indication by red indication flag in window
- ⊙ With remote alarm terminal optional

Note: Subject to change without any notice.

Part No.	PV40-100-MVCR	
In accordance with	EN50539;IEC61643-11:2011; UL1449-4th	
Category IEC/VDE	II/ C	
Protection Mode	Common mode	
Nominal voltage (Vdc)	Un	48VDC
Max. continuous operating voltage (Vdc)	Ucpv	100VDC
Nominal discharge current(8/20)	In	20kA
Max. discharge current(8/20)	Imax	40kA
Voltage protection rating	Up	<800V
Response time	≤ 25ns	
Follow current	No	
Backup fuse(only required if not already provided in mains)	125A gR/gPV	
Operating temperature range	- 40°C ~ + 80°C	
Cross-section of connection wire	Single-strand 35mm ² ; multi-strand 25mm ²	
Mounting	35mm DIN-rail in accordance with EN 50022/DIN46277-3	
Enclosure material	thermoplastic; extinguishing degree UL94 V-0	
Degree of protection	IP20	
Installation width	2 modules, DIN 43880	
Thermal disconnecter	Internal green – normal ; red - failure	
Remote alarm contact	YES	
Approvals, Certifications	CE	
Additional data for Remote Alarm Contacts		
Remote alarm contact type	Isolated Form C	
Switching capability Un/In	AC: 250V/0.5A DC: 250V/0.1A; 125V/0.2A; 75V/0.5A	
Max. Size of connecting wire	Max. 1.5mm ² (or # 16AWG)	

gPV fuse protection

Specification

FUSE & FUSE HOLDER

CH 10 gPV - Fuse - links



General characteristics		UL file: E347771
Rated voltage	1000V d.c. L/R=2ms	
Breaking capacity	10kA d.c.30kA d.c.	
Standards	UL 2579, UL 248-1	
Application	For protection of photovoltaic modules.	

CH 10x38 gPV											
Size	I_n [A]	Code No. "standard contacts" 10kA UL	Code No. "standard contacts" 30kA IEC	Code No. "type SU contacts" 30kA IEC	Pre-arcing Joule integral [A ² s] L/R=2ms	Operating Joule integral [A ² s] L/R=2ms	Power dissipation [0,7 x I_n] P _d [W]	Power dissipation [1] P _d [W]	Weight [g]	Packaging [pcs]	
10 x 38	0,5		002625134	002625131	0,016	0,068	0,2	0,52	10/12	10/500 SU:10/380	
	1		002625138	002625129	1,5	3	0,42	1,0			
	2	002625101	002625065	002625115	1,7	2,3	0,47	1,12			
	3	002625100	002625067	002625113	2,8	5,4	0,65	1,6			
	3,5	002625135	002625068	002625127	2,5	7	0,57	1,4			
	4	002625102	002625069	002625116	3,9	11,7	0,52	1,25			
	5	002625111	002625070	002625124	8	21	0,63	1,49			
	6	002625103	002625071	002625117	10,6	34,6	0,73	1,75			
	7	002625110	002625072	002625114	16	60	0,74	1,74			
	8	002625104	002625073	002625118	17	65	0,8	1,9			
	10	002625105	002625075	002625119	8,3	33	0,97	2,4			
	12	002625106	002625077	002625120	22	73	0,8	1,9			
	13	002625137	002625078	002625128	21	70	1,0	2,3			
	14	002625136	002625079	002625126	28	92	1,3	3,0			
	15	002625112	002625080	002625125	49	145	1,0	2,2			
	16	002625107	002625081	002625121	48	147	1,1	2,6			
	20	002625108	002625085	002625122	86	245	1,3	3,2			
	25*		002625109	002625123	125	289	1,65	4,1			
25		002625139	002625140	110	470	1,65	4,1				

* 900V d.c.

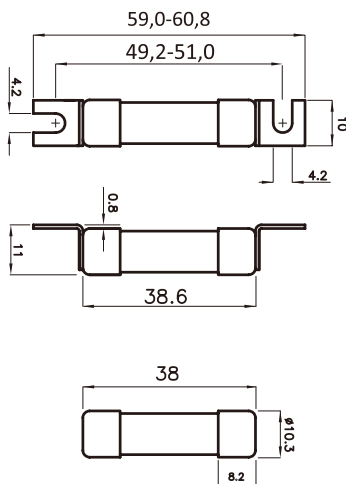

Contacts



Contacts

gPV fuse protection

Specification

CH 10 gPV fuse selection

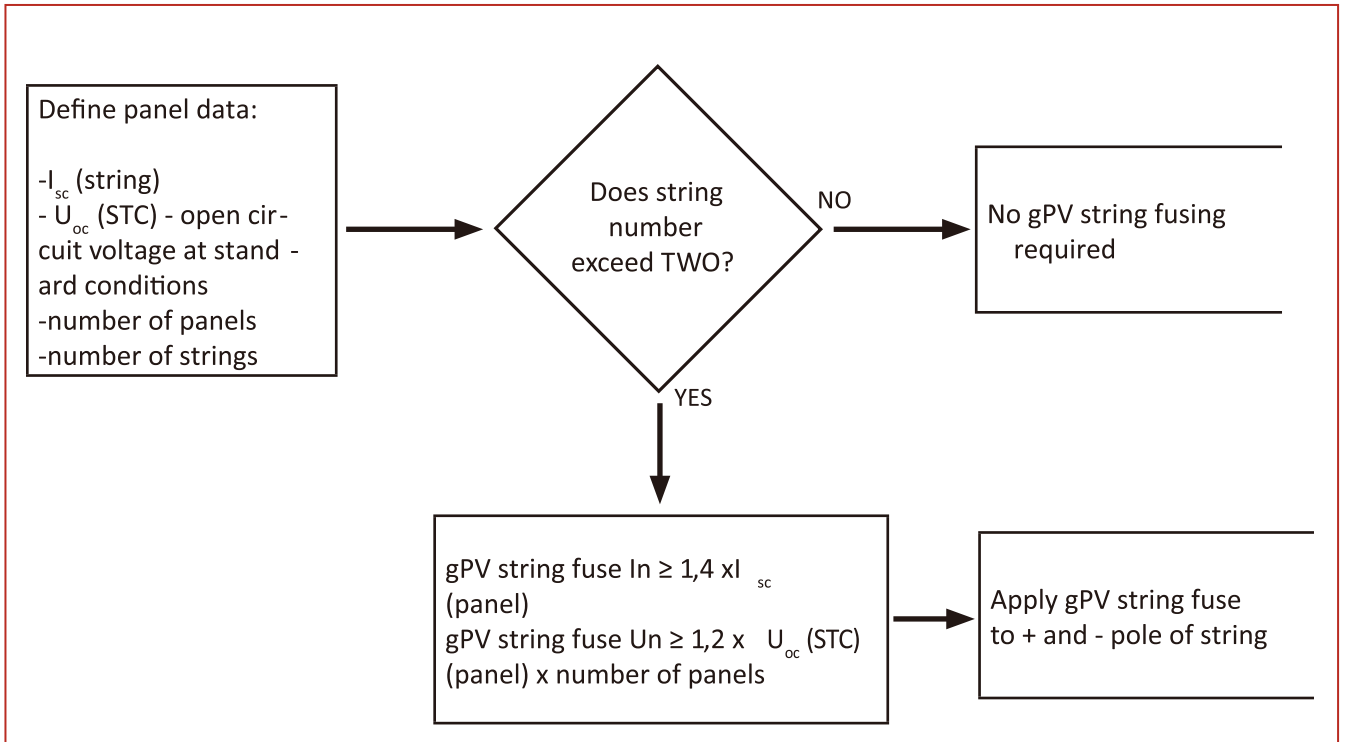

Derating factor 1,4 is defined for ambient temperature max. 45°C.
 Cable cross-section derating factor is not included!

NH gPV fuse selection

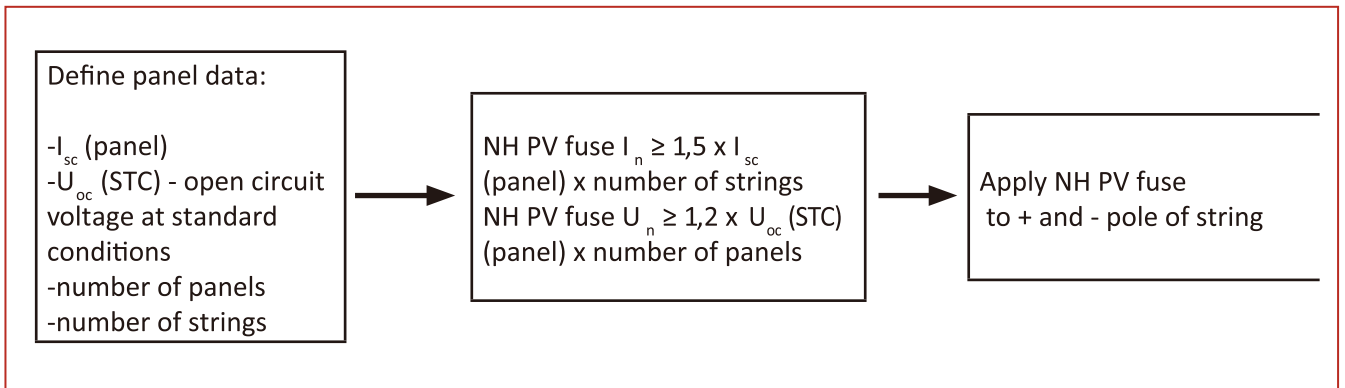

Derating factor 1,5 is defined for ambient temperature max. 45°C.
 Cable cross-section derating factor is not included!



日燭科技有限公司
JD Auspice Co., Ltd

TEL : 886-2-8991-2796

FAX ; 886-2-8991-9298

service@jdauspice.com

www.jdauspice.com