

SR15 DIGITAL SERIES

First class digital pyranometers with various outputs (and heater)

SR15 digital pyranometer series is a range of high-accuracy digital solar radiation sensors. It is "first class" according to the WMO guide and ISO 9060:1990 standard and "Spectrally Flat Class B" in the 2018 revision. Version SR15-D1, equipped with an on-board heater, is compliant in its standard configuration with the requirements for "Class B" PV monitoring systems of the IEC 61724-1:2017 standard.



Figure 1 SR15 digital first class pyranometer series



Figure 2 SR15 pyranometer mounted in PoA (Plane Of Array) on a mast for PV performance monitoring

Introduction

SR15 digital pyranometer series is an all-digital range of solar radiation sensors applied in general high-accuracy observations. The sensor measures the solar radiation received by a plane surface from a 180 ° field of view angle. This quantity, expressed in W/m^2 , is called "hemispherical" solar radiation. SR15 pyranometer can be employed outdoors under the sun, as well as indoors with lamp-based solar simulators. Its orientation depends on the application and may be horizontal, tilted (for plane of array radiation) or inverted (for reflected radiation).

PV system performance monitoring: compliant with IEC class B

IEC 61724-1: Photovoltaic System Performance Monitoring - Guidelines for Measurement, Data Exchange and Analysis - requires heating for Class B monitoring. SR15-D1, with its on-board heater, offers Class B compliance without the need for additional accessories.

Copyright by Hukseflux. Version 1801. We reserve the right to change specifications without prior notice
Page 1/4. For Hukseflux Thermal Sensors go to www.hukseflux.com or e-mail us: info@hukseflux.com

Suggested use

- PV system performance monitoring
- general solar resource monitoring
- indoor simulated solar testing
- meteorological networks

Your benefits

- best measurement accuracy in first class
- improved response time
- with SR15-D1's on-board heater: compliant with IEC 61724-1 Class B in its standard configuration
- on-board calibration history

SR15 digital series design

SR15 first class pyranometer employs a thermal sensor with black coating, two glass domes and an anodised aluminium body. The digital sensor offers output via Modbus RTU over 2-wire RS-485 (version SR15-D1) and via Modbus TTL and 4-20 mA current loop (version SR15-D2A2).

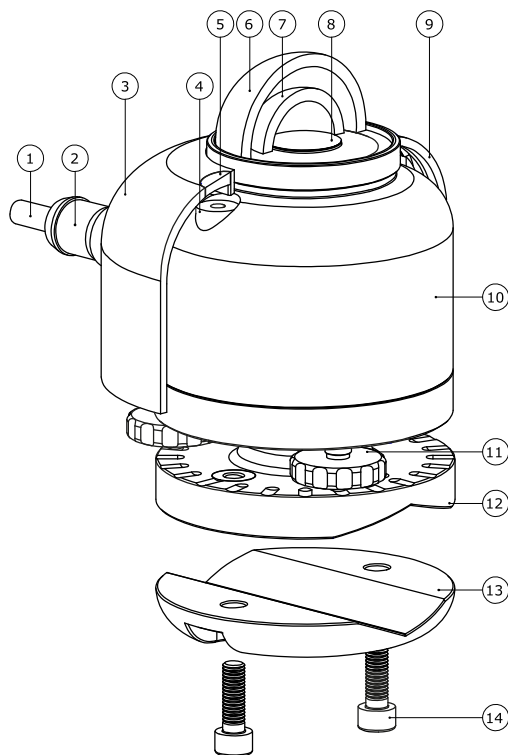

Figure 3 overview of SR15: (1) cable, (2) connector, (3) sun screen, (4) bubble level, (5) bubble level window, (6) outer dome, (7) inner dome, (8) thermal sensor with black coating, (9) quick release system of sun screen, (10) instrument body, (11) levelling feet, (12) optional spring-loaded levelling mount, (13) optional tube mount, (14) screws included with tube mount

Copyright by Hukseflux. Version 1801. We reserve the right to change specifications without prior notice
Page 2/4. For Hukseflux Thermal Sensors go to www.hukseflux.com or e-mail us: info@hukseflux.com

SR15 digital series specifications

Measurand	hemispherical solar radiation
ISO classification	first class pyranometer / spectrally flat class B pyranometer (2018)
IEC 61724-1 compliance	SR15-D1 meets Class B PV monitoring system requirements
Calibration uncertainty	< 1.8 % (k = 2)
Calibration traceability	to WRR
Spectral range	285 to 3000 x 10 ⁻⁹ m
Response time	< 10 s
Zero offset a	5 W/m ² unventilated
Rated operating temperature range	-40 to +80 °C
Temperature response	< ± 2 % (-10 to +40 °C)
Heater	1.5 W at 12 VDC
Standard cable length	5 m
Levelling	optional spring-loaded levelling, with / without tube mount

Output

Version SR15-D1

Communication protocol	Modbus over 2-wire RS-485
Transmission mode	RTU
Output	- irradiance in W/m ² - instrument body temperature in °C
On-board heater	included

Version SR15-D2A2

Communication protocol	Modbus over TTL
Transmission mode	RTU
Output	same as SR15-D1
On-board heater	not included
Analogue output	4-20 mA current loop

Options

- spring-loaded levelling; practical for easy mounting, levelling and instrument exchange on flat surfaces
- tube levelling mount with set of bolts
- mounting brackets
- longer cable; 10 and 20 metres length
- 20 metres extension cable with 2 connectors

Versions

SR15 series offers various versions with industry standard outputs, both digital and analogue, each with several options:

- SR15-D1 digital first class pyranometer, with Modbus RTU over RS-485 output and heater
- SR15-D2A2 digital first class pyranometer, with Modbus RTU over TTL and 4-20 mA output
- SR15-A1 analogue first class pyranometer with millivolt output and heater (please refer to the separate SR15-A1 brochure)

Improved measurement accuracy

Calibration of SR15 pyranometer has been improved; our latest calibration method results in an uncertainty of the sensitivity of 1.8 %, compared to typical uncertainties of higher than 2.8 % for this pyranometer class. SR15's response time is < 10 s, a significant improvement relative to earlier sensors and competitors.

Uncertainty evaluation

The uncertainty of a measurement under outdoor conditions depends on many factors. Guidelines for uncertainty evaluation according to the "Guide to Expression of Uncertainty in Measurement" (GUM) can be found in our manuals. We provide spreadsheets to assist in the process of uncertainty evaluation of your measurement.

Standards

Applicable instrument classification standards are ISO 9060 and WMO-No. 8. Calibration is according to ISO 9847. PV related standards are ASTM E2848 and IEC 61724-1.

Use as sunshine duration sensor

WMO has approved the "pyranometric method" to calculate sunshine duration from pyranometer measurements in WMO-No. 8, Guide to Meteorological Instruments and Methods of Observation. This implies that SR15 may be used, in combination with appropriate software, to estimate sunshine duration. This is much more cost-effective than using a dedicated sunshine duration sensor. Ask for our application note.

Use in National Networks

WMO, the World Meteorological Organization, recommends use of first class pyranometers such as SR15 for network operation.



Figure 4 PMF01 mounting fixture accessory: practical, small footprint, and allowing horizontal and Plane of Array installations on various platforms

Hukseflux Sensor Manager software

For communication between a PC and SR15 digital pyranometer series, the Hukseflux Sensor Manager software is included. It allows the user to plot and export data, and change the SR15 Modbus address and communication settings. Also, the digital outputs may be viewed for sensor diagnostics.



Figure 5 user interface of the Hukseflux Sensor Manager software

See also

- **SR30** next level pyranometers for IEC 61724-1 class A PV monitoring systems
- **SR15-A1** analogue first class pyranometer with millivolt output and heater
- **SR05**, an economical solution often used for monitoring small scale PV systems and large (agro-)meteorological networks
- **PMF01** bracket for tilted installations
- view our complete [range of solar sensors](#)

Our pyranometer [selection guide](#) assists you in choosing the right instrument. Whatever your application is: Hukseflux offers the highest accuracy in every class at the most attractive price level.

For an overview of all SR15 versions and options, and how to order, please take a look at Table 1 on the next page.



Figure 6 several mounting options are offered, such as this spring-loaded levelling mount for easy mounting, levelling and instrument exchanges on flat surfaces



VERSIONS OF SR15 (part numbers)

SR15-D1	digital first class pyranometer with Modbus over RS-485 output and heater
SR15-D1-LM01	digital first class pyranometer with Modbus over RS-485 output and heater, with levelling mount, for spring-loaded levelling and mounting SR15 on a surface
SR15-D1-TLM01	digital first class pyranometer with Modbus over RS-485 output and heater, with tube levelling mount, for spring-loaded levelling and mounting SR15 on a tube
SR15-D2A2	digital first class pyranometer with Modbus over TTL and 4-20 mA output
SR15-D2A2-LM01	digital first class pyranometer with Modbus over TTL and 4-20 mA output, with levelling mount, for spring-loaded levelling and mounting SR15 on a surface
SR15-D2A2-TLM01	digital first class pyranometer with Modbus over TTL and 4-20 mA output, with tube levelling mount, for spring-loaded levelling and mounting SR15 on a tube
SR15-A1	analogue first class pyranometer with millivolt output and heater (see separate SR15-A1 brochure and manual)
SR15-A1- LM01	analogue first class pyranometer with millivolt output and heater, with levelling mount, for spring-loaded levelling and mounting SR15 on a surface (see separate SR15-A1 brochure and manual)
SR15-A1- TLM01	analogue first class pyranometer with millivolt output and heater, with tube levelling mount, for spring-loaded levelling and mounting SR15 on a tube (see separate SR15-A1 brochure and manual)

**CABLE FOR SR15,
with female M12-A connector at sensor end, stripped over 0.15 m, and conductors with ferrules**

`-05' after SR15 part number	standard cable length: 5 m
`-10' after SR15 part number	cable length: 10 m
`-20' after SR15 part number	cable length: 20 m

**CABLE EXTENSION FOR SR15,
with male and female M12-A connectors**

C07E-20	cable length: 20 m
---------	--------------------



Figure 7 SR15 with optional tube levelling mount

About Hukseflux

Hukseflux Thermal Sensors offers measurement solutions for the most challenging applications. We design and supply sensors as well as test & measuring systems, and offer related services such as calibration, engineering and consultancy. Hukseflux is ISO 9001 certified. Hukseflux sensors, systems and services are offered worldwide via our office in Delft, the Netherlands and local distributors.

Interested in this product?
E-mail us at: service@jdauspice.com